

BEIJING HUADE HYDRAULIC INDUSTRIAL GROUP CO.,LTD.	Check-Q-meter type FD			RE27551/12.2004
	Size 12 ,16,25,32	up to 31.5MPa	up to 560 L/min	Replaces; RE27551/05.2001

Features:

- Porting pattern to DIN 24 340, from D,ISO 5781 and CETOP-RP 121H
- Pilot operated check valve, leak-free,- The check-Q-meter controls the returning flow q_{v2} in relation to the flow being directed into the opposite side of the actuator q_{v1} . With cylinders the area ratio($q_{v2} = q_{v1} \varphi$) has to be taken into account,
- By-pass valve, free-flow in opposite direction,
- Optional built-in secondary pressure relief valve (only for valve with flange connections).

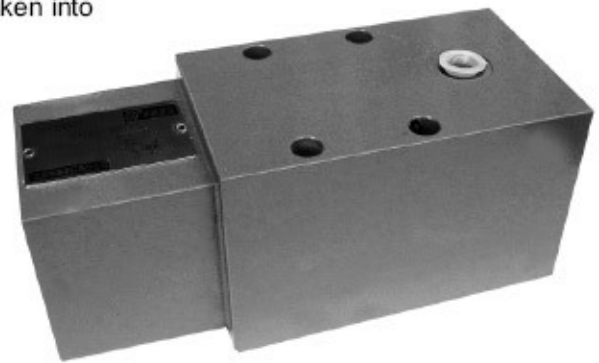

Functional, section

Check-Q-meters are used in hydraulic systems to influence the speeds of hydraulic motors and cylinders independent of the load (prevents running away). In addition there is an isolator function for pipe burst safety. The check-Q-meter comprises basically of the housing (1), main poppet (2), pilot part (3), pilot spool (4), damping spool (5) and pilot damping (6).

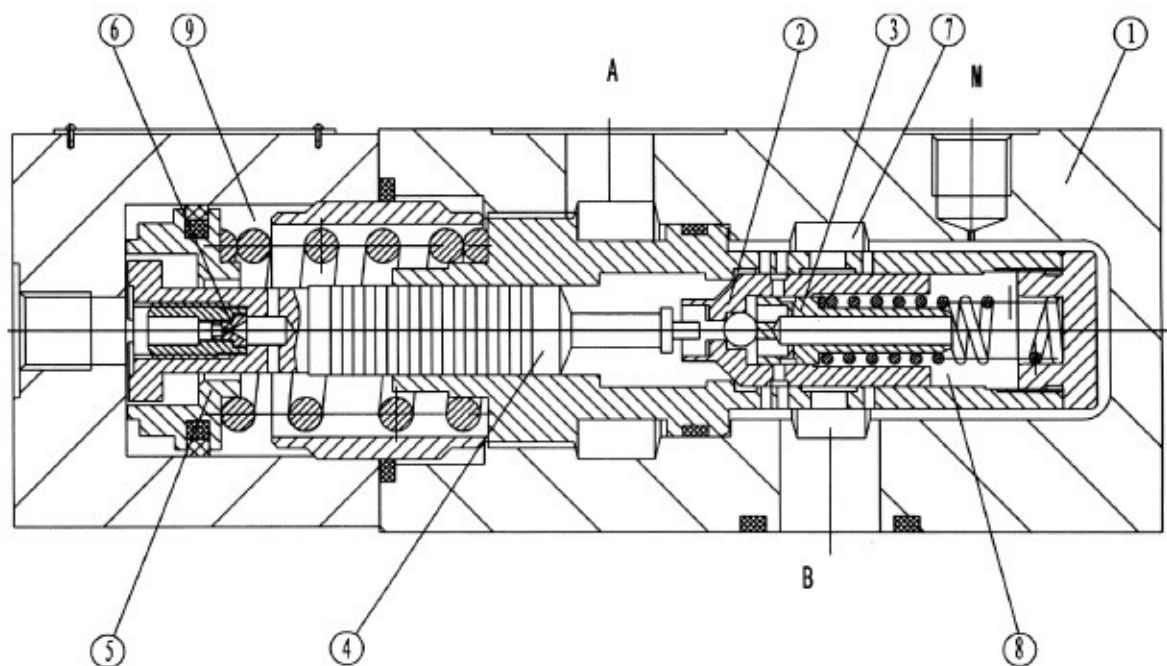

Circuit examples

Note:

Two check-Q-meters cannot be used to control two cylinders which are forced mechanically to move together, as synchronisation and the same pressure cannot be guaranteed in each cylinder.

Therefore, the cylinders have to be equipped with two pilot operated check valves, type SL. The check-Q-meter is fitted in a common line.

In this case, the load pressure must not exceed 20MPa !

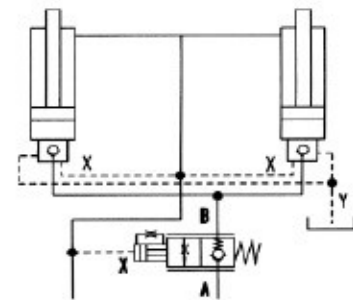

Characteristic curves (measured at $v = 41 \text{ mm}^2$ and $t = 50^\circ\text{C}$)

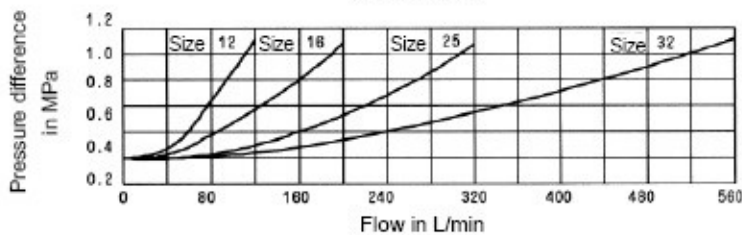
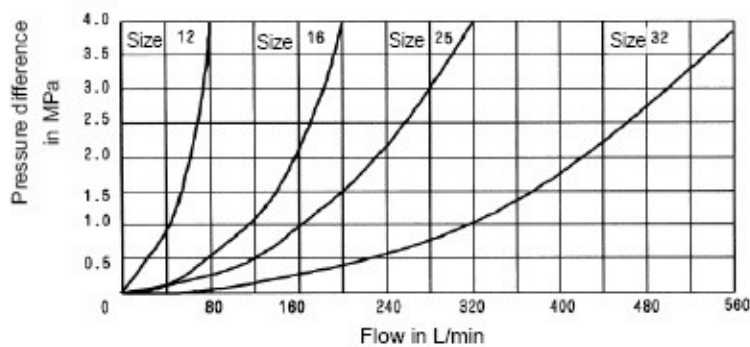

Pressure difference Δp in relation to flow q_v , measured at throttle position:
Throttle fully open
($P_x = 6 \text{ MPa}$)
B to A

Pressure difference in MPa
Flow in L/min
Pressure difference Δp in relation to flow q_v , measured over the check valve
A to B

Technical data (for applications outside these parameters, please consult us!)

Operating pressure, ports A, X	(MPa)	to 31.5
Operating pressure, port B	(MPa)	to 42
Pilot pressure, port X (flow control range)	(MPa)	min. 2 to 3.5, max. 31.5
Cracking pressure, A to B	(MPa)	0.2
Setting pressure for secondary pressure relief valve	(MPa)	to 40
Flow	(L/min)	80 (size12) 200 (size16) 320 (size25) 560 (size32)
Area ratio of the pre-opening		$\frac{\text{poppet seat area}}{\text{area of pilot spool}} = \frac{1}{20}$
Pressure fluid temperature range	($^\circ\text{C}$)	-30 to +80
Viscosity range	(mm^2/s)	10 to 800
Pressure fluid		Mineral oil (for NBR seal) or Phosphate ester (for FPM seal)

Unit dimensions: for SAE flange connections, without secondary pressure relief valve

(Dimensions in mm)

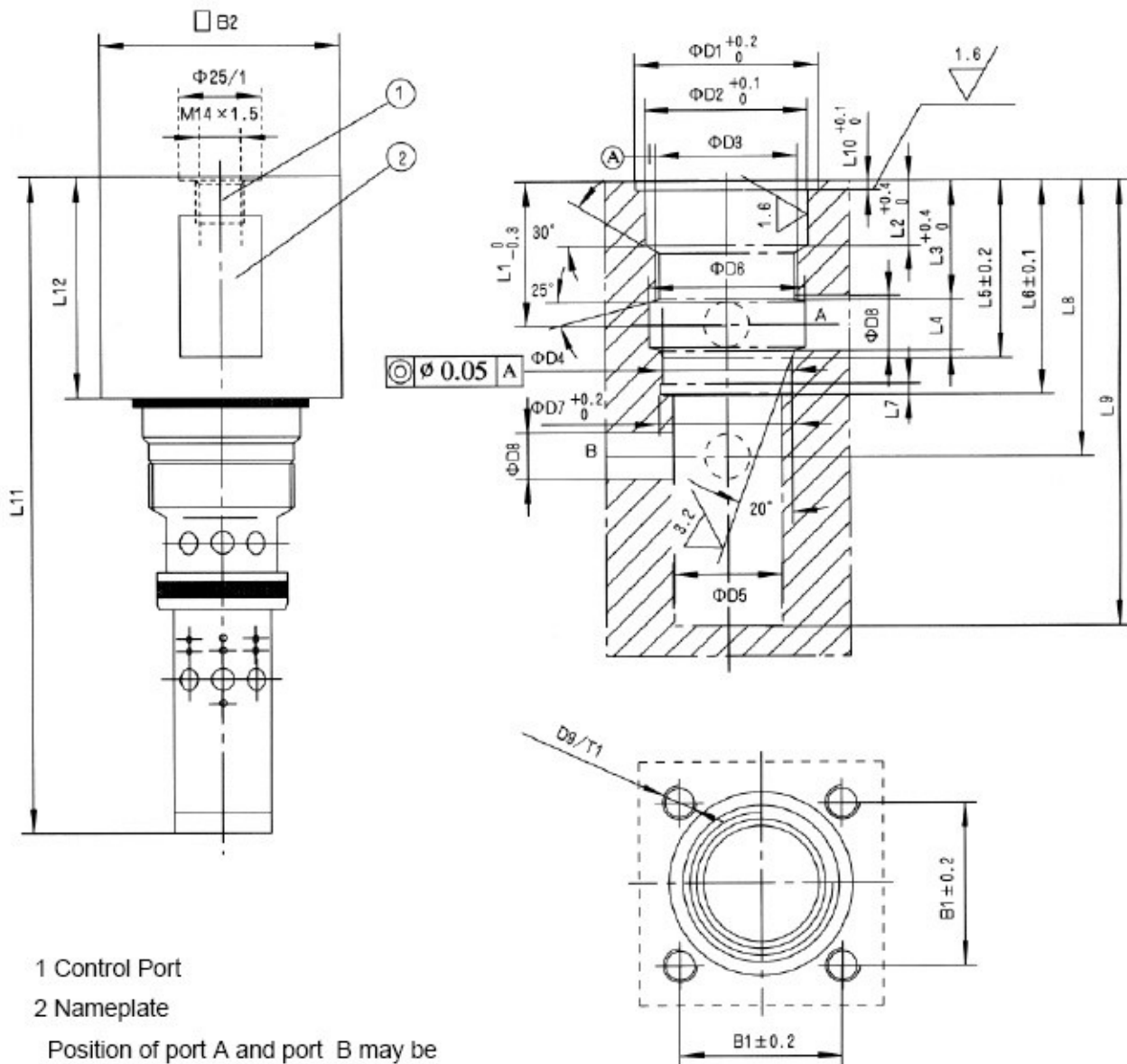

- 1 Control Port
- 2 Nameplate

Position of port A and port B may be arranged as desired, but do not occupy the position of the fixing screw holes

Type	B1	B2	D1	D2	D3	D4	D5	D6	D7	D8	D9	T1	L1	L2	L3	L4	L5	L6
FD12KA10	48	70	54	46	M42X2	38	34	46	38.6	16	M10	16	39	16	32	15.5	50.6	60
FD16KA10	48	70	54	46	M42X2	38	34	46	38.6	16	M10	16	39	16	32	15.5	50.6	60
FD25KA10	56	80	60	54	M52X2	48	40	60	48.6	25	M12	19	50	19	39	22	65	80
FD32KA10	66	95	72	65	M64X2	58	52	74	58.6	30	M16	23	52	19	40	25	71	85

Type	L7	L8	L9	L10	L11	L12	Size	Valve fixing screws/tightening torque M_A (Nm)	Weight	
FD12KA12	3	78	128	2.75	191	65	12	4-M10 × 70-10.9	69	2.8kg
FD16KA12	3	78	128	2.75	191	65	12	4-M10 × 70-10.9	69	2.8kg
FD25KA12	4	105	182	2.3	253	75	25	4-M12 × 80-10.9	120	2.8kg
FD32KA11	4	115	198	2.3	289	94	32	4-M16 × 100-10.9	295	7.5kg

Unit dimensions: for sub-plate mounting

(Dimensions in mm)

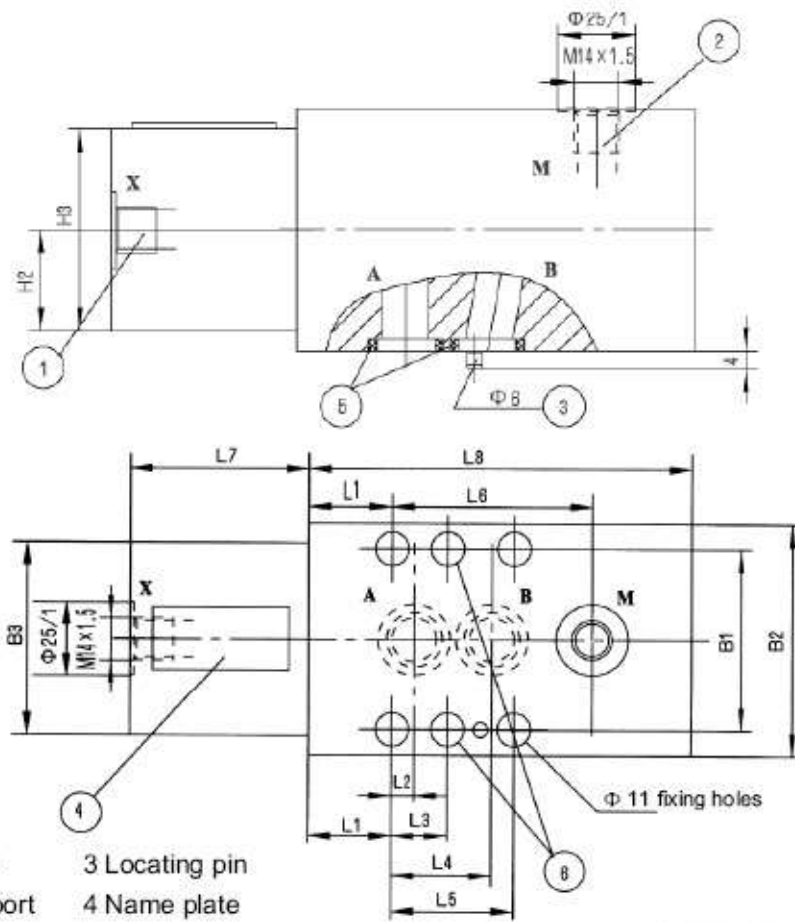

- 1 Control port
- 2 Measuring port
- 3 Locating pin
- 4 Name plate
- 5 O-ring
- 6 Valve fixing holes(for size 32,6,the other 4)

Subplates for:see page 70

- NG12, 16: G460/01 G460/02
- G461/01 G461/02
- NG25: G412/01 G412/02
- G413/01 G413/02
- NG32: G414/01 G414/02
- G415/01 G415/02

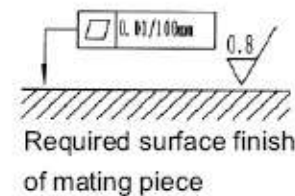

Type	B1	B2	B3	H1	H2	H3	L1	L2
FD 12 PA12	66.5	85	70	85	42.5	70	32	7
FD 16 PA12	66.5	85	70	85	42.5	70	32	7
FD 25 PA12	79.5	100	80	100	50	80	39	11
FD 32 PA11	97	120	95	120	60	95	35.5	16.5

Type	L3	L4	L5	L6	L7	L8	Weight	O-Ring
FD 12 PA12	-	35.5	43	73	65	140	9kg	21.3x2.4
FD 16 PA12	-	35.5	43	73	65	140	9kg	21.3x2.4
FD 25 PA12	-	49	60.5	109	75	200	18kg	29.82x2.62
FD 32 PA11	42	67.5	84	119.5	94	215	24kg	38x3

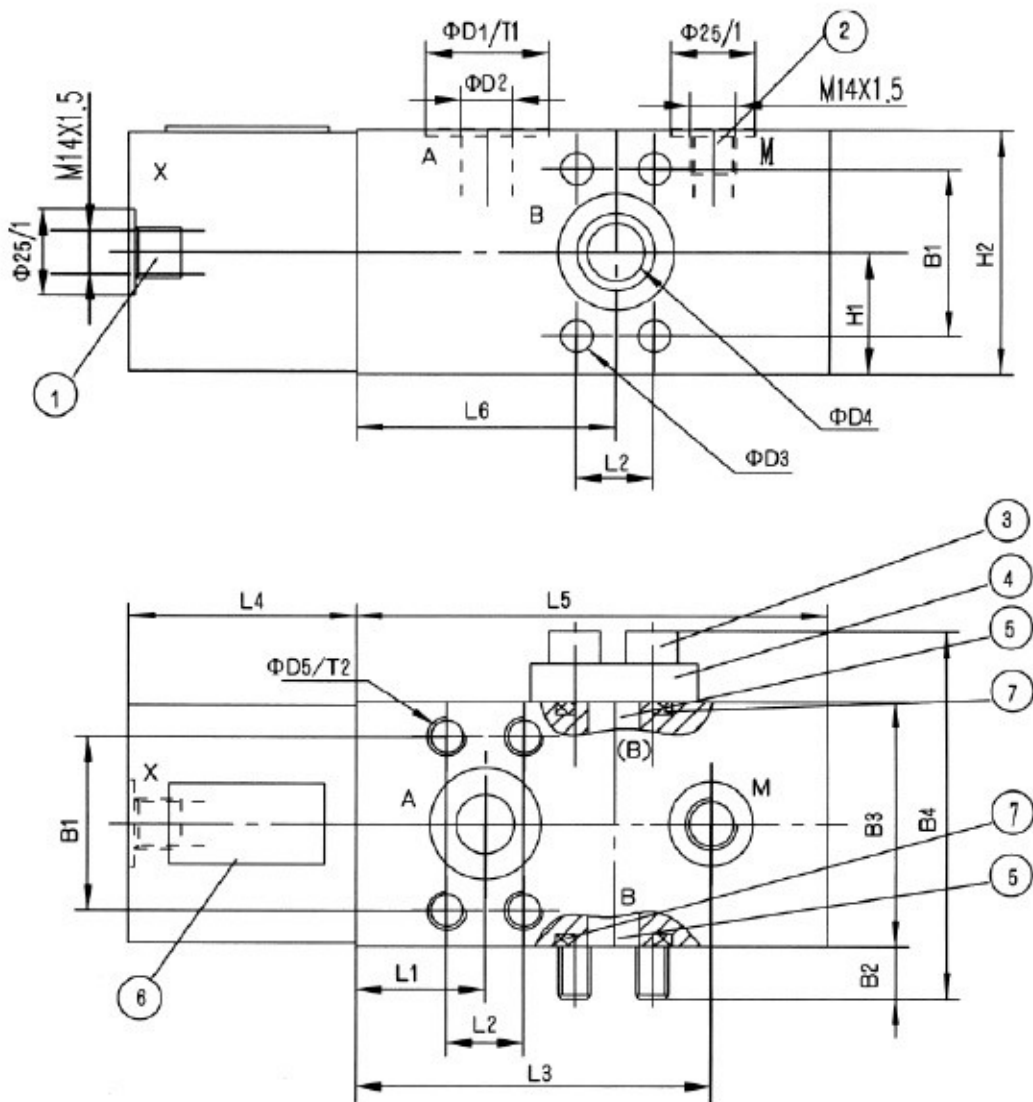

- 1 Control port 3 Flange fixing screws 5 Optional port B 7 O-ring
- 2 Measuring port 4 Blanking flange 6 Nameplate

Type	B1	B2	B3	B4	D1	D2	D3	D4	D5	H1	H2
FD12FA12	50.85	16.5	72	110	42	18	10.5	18	M10	36	72
FD16FA12	50.85	16.5	72	110	42	18	10.5	18	M10	36	72
FD25FA12	57.2	14.5	90	132	50	25	13.5	25	M12	45	90
FD32FA11	66.7	20	105	154	56	30	15	30	M14	50	105

Type	L1	L2	L3	L4	L5	L6	T1	T2	Weight	O-Ring
FD12FA10	39	23.8	105	65	140	78	0.2	15	7kg	25x3.5
FD16FA10	39	23.8	105	65	140	78	0.2	15	7kg	25x3.5
FD25FA10	50	27.8	148	75	200	105	0.2	18	16kg	32.92x3.53
FD32FA10	52	31.6	155	94	215	115	0.2	21	21kg	37.7x3.53

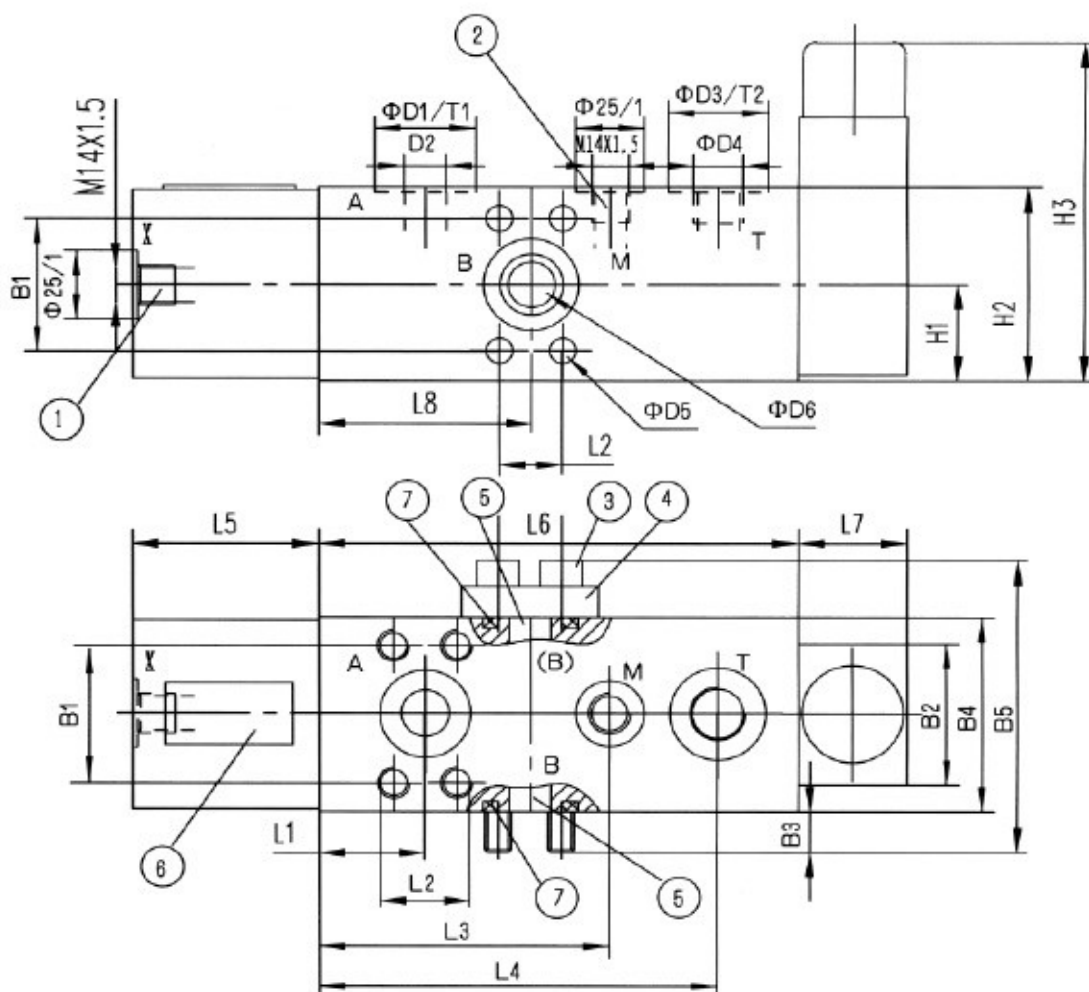

- 1 Control port 3 Flange fixing screws 5 Optional port B 7 O-ring
- 2 Measuring port 4 Blanking flange 6 Nameplate

Type	B1	B2	B3	B4	B5	D1	D2	D3	D4	D5	D6	D7	H1	H2
FD12 FB12	50.8	49	16.5	72	110	42	18	34	M22x1.5	10.5	18	M10	36	72
FD16 FB12	50.8	49	16.5	72	110	42	18	34	M22x1.5	10.5	18	M10	36	72
FD25 FB12	57.2	78	14.5	90	132	50	25	42	M27x2	13.5	25	M12	45	90
FD32 FB11	66.7	78	20	105	154	56	30	42	M27x2	15	30	M14	50	105

Type	H1	L1	L2	L3	L4	L5	L6	L7	L8	T1	T2	T3	Weight	O-Ring
FD12 FB12	118	39	23.8	105	141.5	65	162	38	78	0.2	1	15	9Kg	25x3.5
FD16 FB12	118	39	23.8	105	141.5	65	162	38	78	0.2	1	15	9Kg	25x3.5
FD25 FB12	145	50	27.8	148	198	75	225	50	105	0.2	1	18	18Kg	32.92x3.53
FD32 FB11	145	52	31.6	155	215	94	240	50	115	0.2	1	21	24Kg	37.7x3.53

Notice

1. The fluid must be filtered. Minimum filter fineness is 20 μm .
2. The tank must be sealing up and an air filter must be installed on air entrance.
3. Products without subplate when leaving factory, if need them, please ordering specially.
4. Valve fixing screws must be high intensity level (class 10.9). Please select and use them according to the parameter listed in the sample book.
5. Roughness of surface linked with the valve is required to $\sqrt{0.8}$.
6. Surface finish of mating piece is required to 0.01/100mm.